

Ultra96 Hardware User's Guide

Revision 1

Version 0.9

Contents

1	Document Control	3
2	Version History	3
3	Introduction	3
3.1	Glossary	4
3.2	Reference Documents	4
4	Ultra96 Architecture and Features	5
4.1	List of Features	5
4.2	Ultra96 Block Diagram	6
5	Functional Description	7
5.1	Zynq UltraScale+ MPSoC	7
5.1.1	SBVA484 Package	8
5.1.2	MIO Configuration	9
5.1.3	Programmable Logic	12
5.1.3.1	Low Speed Expansion Connector	12
5.1.3.2	High Speed Expansion Connector	14
5.2	LPDDR4 Memory	15
5.3	microSD Card	15
5.4	USB	16
5.4.1	USB5744 Implementation Details	16
5.5	Wi-Fi / Bluetooth	17
5.5.1	Wi-Fi	17
5.5.2	Bluetooth	17
5.5.3	Bluetooth Audio	17
5.6	Mini DisplayPort	17
5.7	UART	17
5.8	I2C	18
5.9	User LEDs	18
5.10	MPSoC Thermal Bracket with Fan	18
6	Configuration and Debug	19
6.1	Boot Mode	19
6.2	JTAG Configuration and Debug	19
7	Power	20
7.1	External Power Connection	20
7.2	Power Estimation Using XPE	20
7.3	Power Regulators	21
7.4	Power Sequence	22
8	Clocks	23
9	Reset	23
10	Getting Help and Support	23

1 Document Control

Document Version: 0.9

Document Date: 18 March 2018

2 Version History

Version	Date	Comment
0.9	18 Mar 2018	Preliminary release of Ultra96 Hardware User's Guide

3 Introduction

The main purposes of the Ultra96 Kit are:

- Provide a Xilinx entry in the 96Boards community
- Combine Arm processing with programmable logic in a convenient and expandable board
- Showcase a wide range of potential peripherals and acceleration engines in the programmable logic that is not available from other 96Boards offerings
- Be a low-cost starter kit for Zynq UltraScale+ MPSoC developers
- Showcase hardware acceleration for software bottlenecks
- Allow expansion to a variety of sensors and peripherals through the 96Boards mezzanine connectors
- Target a number of applications for development, including:
 - Artificial Intelligence
 - Machine Learning
 - IoT/Cloud connectivity for add-on sensors
 - Embedded Computing
 - Robotics
 - Wireless design and demonstrations using Wi-Fi and Bluetooth

3.1 Glossary

Term	Definition
PS	Zynq UltraScale+ MPSoC Processing System
PL	Zynq UltraScale+ MPSoC Programmable Logic
MIO	PS Multiplexed Input Output Pins
POR	Power On Reset
APU	Application Processing Unit
RPU	Real-time Processing Unit
GPU	Graphics Processing Unit
SYSMON	System Monitor
HD	High Density PL I/O Pins
HP	High Performance PL I/O Pins
PMBus	Power Management Bus

3.2 Reference Documents

- [1] [Zynq UltraScale+ MPSoC Overview](#)
- [2] [Zynq UltraScale+ MPSoC DC and AC Switching Characteristics](#)
- [3] [Zynq UltraScale+ MPSoC Technical Reference Manual](#)
- [4] [Zynq UltraScale+ MPSoC Packaging and Pinout Product Specification](#)
- [5] [Zynq UltraScale+ MPSoC PCB Design Guide](#)
- [6] [UltraScale Architecture SelectIO Resources](#)
- [7] [SBVA484 Package File](#)
- [8] [Xilinx Vivado Design Suite](#)
- [9] [Xilinx Software Development Kit](#)
- [10] [96Boards Specification](#)
- [11] [WiLink8 2.4GHz WiFi + Bluetooth Module](#)
- [12] [USB3320 Hi-Speed USB 2.0 ULPI Transceiver](#)
- [13] [USB5744 Smart Hub](#)
- [14] [Micron MT53B512M32D2NP-062 WT:C LPDDR4 SDRAM datasheet](#)
- [15] [Delkin Devices Utility Industrial MLC microSD](#)

4 Ultra96 Architecture and Features

This section summarizes the features of the development board, followed by functional descriptions of each circuit.

4.1 List of Features

The Ultra96 Developer Kit supports the following features:

- Zynq UltraScale+ MPSoC ZU3EG SBVA484
- Storage
 - Micron 2 GB (512M x32) LPDDR4 Memory
 - MicroSD Socket
 - Ships with Delkin Utility MLC Industrial 16GB card
- Wi-Fi / Bluetooth
- DisplayPort
- 1x USB 3.0 Type Micro-B upstream port
- 2x USB 3.0 Type A downstream ports
- 40-pin Low-speed expansion header
- 60-pin High speed expansion header
- Mounted on thermal bracket with fan

Note that there is no on-board, wired Ethernet interface. All communications must be done via USB, Wi-Fi, JTAG, or expansion interface.

4.2 Ultra96 Block Diagram

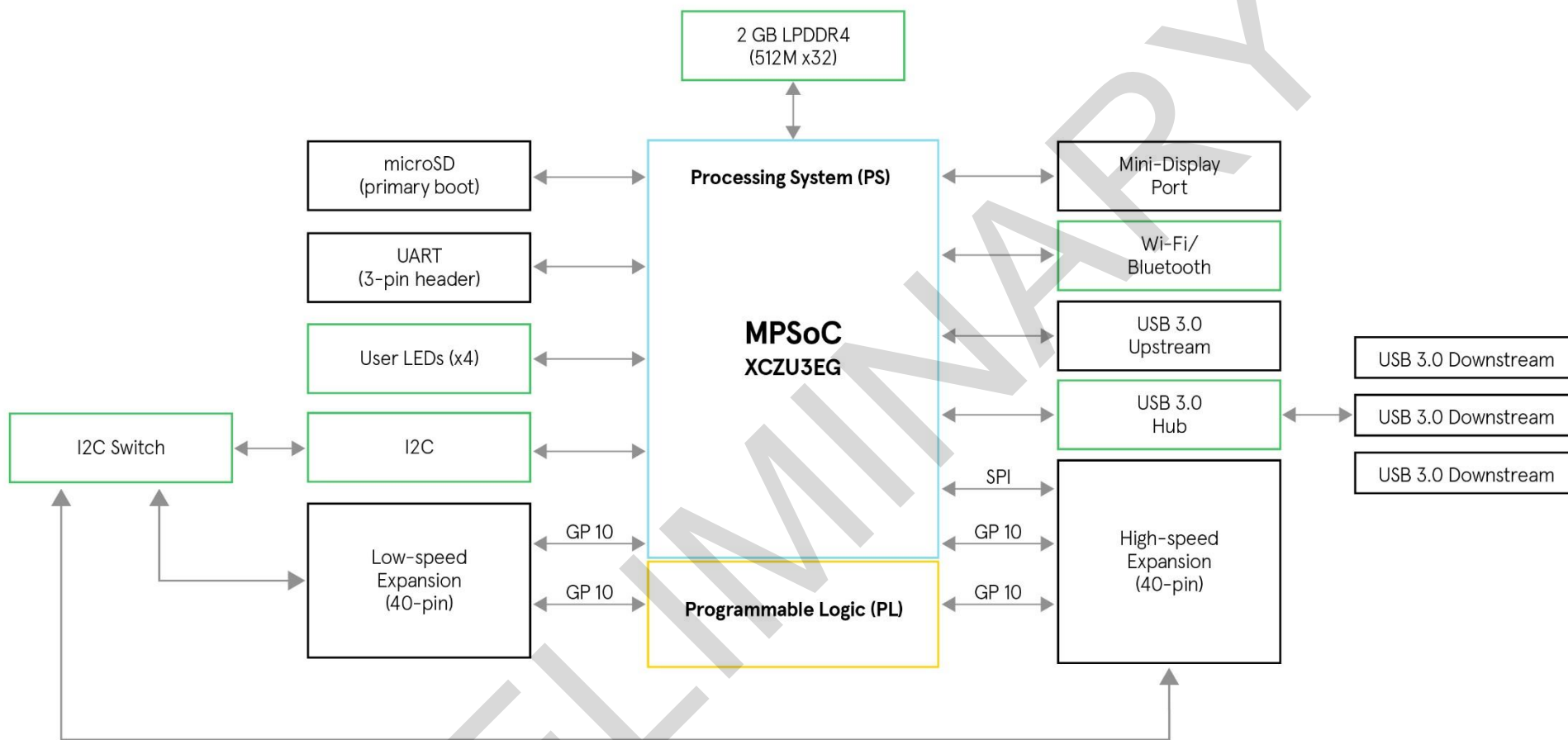

Figure 1 – Ultra96 Block Diagram

5 Functional Description

The following sections provide brief descriptions of each feature provided on the Ultra96 board.

5.1 Zynq UltraScale+ MPSoC

The Zynq UltraScale+ MPSoC ZU3EG device (in the SBVA484 package) contains:

- Processor System (PS):
 - **Application Processing Unit**
Quad-core ARM Cortex-A53 MPCore with CoreSight; NEON & Single/Double Precision Floating Point; 32KB/32KB L1 Cache, 1MB L2 Cache
 - **Real-Time Processing Unit**
Dual-core ARM Cortex-R5 with CoreSight; Single/Double Precision Floating Point; 32KB/32KB L1 Cache, and TCM
 - **Embedded and External Memory**
256KB On-Chip Memory w/ECC; External DDR4; DDR3; DDR3L; LPDDR4; LPDDR3; External Quad-SPI; NAND; eMMC
 - **General Connectivity**
214 PS I/O; UART; CAN; USB 2.0; I2C; SPI; 32b GPIO; Real Time Clock; WatchDog Timers; Triple Timer Counters
 - **High-Speed Connectivity**
4 PS-GTR; PCIe Gen1/2; Serial ATA 3.1; DisplayPort 1.2a; USB 3.0; SGMII
 - **Graphic Processing Unit**
ARM Mali™-400 MP2; 64KB L2 Cache
- Programmable Logic (PL)
 - System Logic Cells 154,350
 - CLB Flip-Flops 141,120
 - CLB LUTs 70,560
 - Distributed RAM (Mb) 1.8
 - Block RAM Blocks 216
 - Block RAM (Mb) 7.6
 - UltraRAM Blocks 0
 - UltraRAM (Mb) 0
 - DSP Slices 360
 - CMTs 3
 - System Monitor 2
- I/O
 - Max MIO 78
MIO = multiplexed I/O (up to three banks of 26 I/Os) with support for I/O voltage of 1.8V or 3.3V
 - Max. PL HP I/O 156
HP = High-performance I/O with support for I/O voltage from 1.0V to 1.8V
 - Max. PL HD I/O 96
HD = High-density I/O with support for I/O voltage from 1.2V to 3.3V

5.1.1 SBVA484 Package

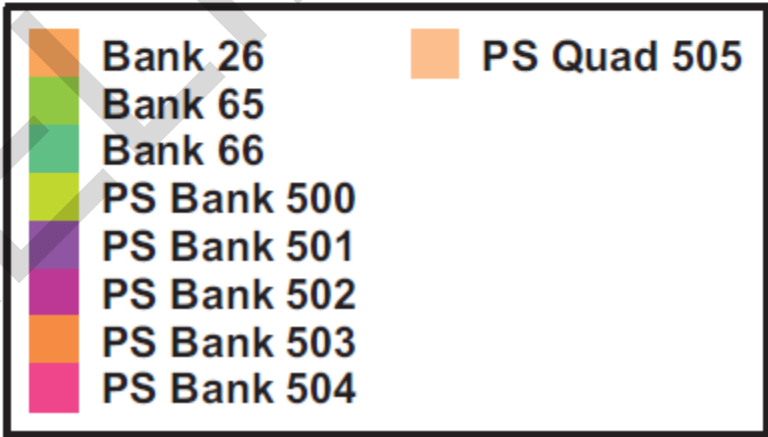
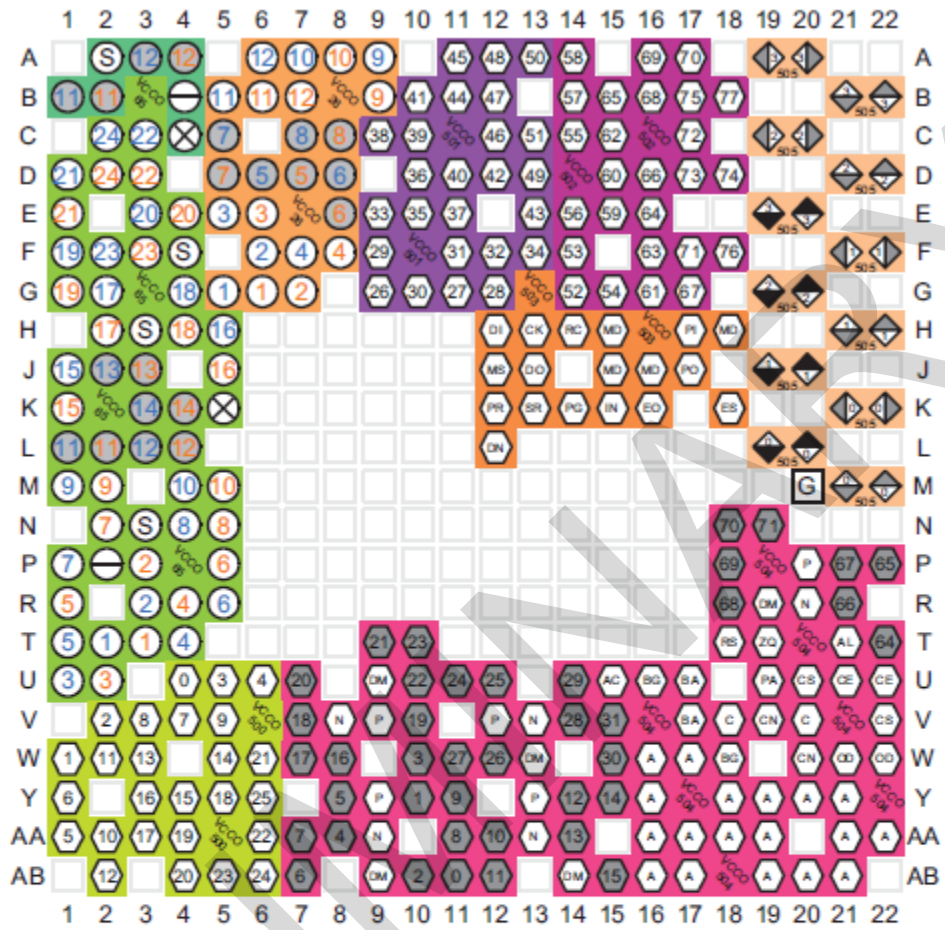

Figure 2 – SBVA484 Package Diagram

5.1.2 MIO Configuration

Table 1 – MIO Overview

Bank 500 1.80V	0	1	2	3	4	5	6	7	8	9	10	11	12	13	14	15	16	17	18	19	20	21	22	23	24	25
	UART1	UART0	I2C1	SPI1	WE	BE	SPI1			I2C	SD0			LED			SD0	PB	SD0	USB						

Bank 501 1.80V	26	27	28	29	30	31	32	33	34	35	36	37	38	39	40	41	42	43	44	45	46	47	48	49	50	51
	PI	DPAUX			INA	PMIC	PK	TP	LSE	SPI0	LSE	SPI0		LSE	SD1											

Bank 502 1.80V	52	53	54	55	56	57	58	59	60	61	62	63	64	65	66	67	68	69	70	71	72	73	74	75	76	77
	USB0												USB1												IW	PMI

UART1 - Header

UART0 - Bluetooth (+ PL RTS/CTS)

I2C1 - I2C Hub

SPI1 - HS Expansion Header

WE - (GPIO) WiFi Enable

BE - (GPIO) Bluetooth Enable

I2C - (GPIO) I2C Hub Reset

SD0 - SD Card (3.3V level shifter)

LED - (GPIO) User LEDs

PB - (GPIO) User Pushbutton

USB - (GPIO) USB Hub Vbus detect

PI - (GPIO) Power Pushbutton Controller INT_B (PMU input)

DPAUX - DisplayPort Auxiliary Signals

INA - (GPIO) INA226 PMBUS Alert (PMU Input)

PMIC - (GPIO) FPU, PL power control (PMU Output)

PK - (GPIO) Power Pushbutton Controller KILL_B (PMU output)

TP - (GPIO) Test Point (PMU Output)

LSE - (GPIO) LS Expansion Header GPIO[A..L]

SPI0 - LS Expansion Header

SD1 - WiFi

USB0 - Upstream USB

USB1 - Downstream USB, Hub

IW - (GPIO) WiFi IRQ

PMI - (GPIO) PMIC Interrupt

Table 2 – MIO Details

Bank	Pin #	Device	Signal	I/O	Notes
500	0	UART1	MIO0_UART1_TX	O	UART Header J6
	1		MIO1_UART1_RX	I	
	2	UART0	MIO2_UART0_RX_BT_HCI_TX	I	WL1831 B
	3		MIO3_UART0_TX_BT_HCI_RX	O	
	4	I2C1	MIO4_I2C1_SCL	O	
	5		MIO5_I2C1_SDA	IO	
	6	SPI1	MIO6_SPI1_SCLK	O	Hi-speed Expansion Header
	7	GPIO	MIO7_WLAN_EN	O	WL1831 WiFi enable
	8	GPIO	MIO8_BT_EN	O	WL1831 BT enable
	9	SPI1	MIO9_SPI1_CS	O	Hi-speed Expansion Header
	10		MIO10_SPI1_MISO	I	
	11		MIO11_SPI1_MOSI	O	
	12	GPIO	MIO12_I2C_MUX_RESET_B	O	I2C Mux reset
	13	SD0	MIO13_SD0_DAT0	IO	SDIO0 Data 0
	14		MIO14_SD0_DAT1	IO	SDIO0 Data 1
	15		MIO15_SD0_DAT2	IO	SDIO0 Data 2
	16		MIO16_SD0_DAT3	IO	SDIO0 Data 3
	17	GPIO	MIO17_PS_LED3	O	User LED 3
	18		MIO18_PS_LED2	O	User LED 2
	19		MIO19_PS_LED1	O	User LED 1
	20		MIO20_PS_LED0	O	User LED 0
	21	SD0	MIO21_SD0_CMD	IO	SDIO0 Command
	22		MIO22_SD0_CLK	O	SDIO0 Clock
	23	GPIO	MIO23_GPIO_PB	I	User Pushbutton
	24	SD0	MIO24_SD0_DETECT	I	SDIO Card Detect
25	GPIO	MIO25_VBUS_DET	O	USB Hub VBUS	
501	26	GPIO	MIO26_POWER_INT_B	I	LTC2950 Pushbutton On/Off Controller Interrupt, Pushbutton turn-off event detected
	27	DPAUX	MIO27_DP_AUX_OUT	O	DPAUX single-ended output
	28		MIO28_DP_HPD	I	DPAUX Hot Plug Detect
	29		MIO29_DP_OE	O	DPAUX Output Enable
	30		MIO30_DP_AUX_IN	I	DPAUX single-ended input
	31	GPIO	MIO31_INA226_PMBUS_ALERT	I	INA226 Alert
	32	GPIO	MIO32_PS_FP_PWR_EN	O	PMU power off Full Power Domain

	33	GPIO	MIO33_PL_PWR_EN	O	PMU power off PL
	34	GPIO	MIO34_POWER_KILL_B	O	LTC2950 Pushbutton On/Off Controller Release enable output, power off system
	35	GPIO		IO	Test Point
	36	GPIO	MIO36_PS_GPIO1_0	IO	Low-speed Expansion GPIO-C
	37	GPIO	MIO37_PS_GPIO1_1	IO	Low-speed Expansion GPIO-D
	38	SPI	MIO38_SPI0_SCLK	O	SPI Serial Clock
	39	GPIO	MIO39_PS_GPIO1_2	IO	Low-speed Expansion GPIO-E
	40	GPIO	MIO40_PS_GPIO1_3	IO	Low-speed Expansion GPIO-F
	41	SPI0	MIO41_SPI0_CS0	O	SPI Chip Select 0
	42	SPI0	MIO42_SPI0_MISO	I	SPI Data In
	43	SPI0	MIO43_SPI0_MOSI	O	SPI Data Out
	44	GPIO	MIO44_PS_GPIO1_4	IO	Low-speed Expansion GPIO-G
	45	GPIO	MIO45_PS_GPIO1_5	IO	Low-speed Expansion GPIO-H
	46	SDIO	MIO46_SD1_D0	IO	SDIO1 Data 0
	47	SD1	MIO47_SD1_D1	IO	SDIO1 Data 1
	48	SD1	MIO48_SD1_D2	IO	SDIO1 Data 2
	49	SD1	MIO49_SD1_D3	IO	SDIO1 Data 3
	50	SD1	MIO50_SD1_CMD	O	SDIO1 Command
	51	SD1	MIO51_SD1_CLK	O	SDIO1 Clock
502	52	USB0	MIO52_USB0_CLK	I	USB0 Clock
	53		MIO53_USB0_DIR	I	USB0 Data bus direction
	54		MIO54_USB0_DATA2	IO	USB0 Data 2
	55		MIO55_USB0_NXT	I	USB0 Data flow
	56		MIO56_USB0_DATA0	IO	USB0 Data 0
	57		MIO57_USB0_DATA1	IO	USB0 Data 1
	58		MIO58_USB0_STP	O	USB0 Stop transfer
	59		MIO59_USB0_DATA3	IO	USB0 Data 3
	60		MIO60_USB0_DATA4	IO	USB0 Data 4
	61		MIO61_USB0_DATA5	IO	USB0 Data 5
	62		MIO62_USB0_DATA6	IO	USB0 Data 6
	63		MIO63_USB0_DATA7	IO	USB0 Data 7

64	USB1	MIO64_USB1_CLK	I	USB1 Clock	
65		MIO65_USB1_DIR	I	USB1 Data bus direction	
66		MIO66_USB1_DATA2	IO	USB1 Data 2	
67		MIO67_USB1_NXT	I	USB1 Data flow	
68		MIO68_USB1_DATA0	IO	USB1 Data 0	
69		MIO69_USB1_DATA1	IO	USB1 Data 1	
70		MIO70_USB1_STP	O	USB1 Stop transfer	
71		MIO71_USB1_DATA3	IO	USB1 Data 3	
72		MIO72_USB1_DATA4	IO	USB1 Data 4	
73		MIO73_USB1_DATA5	IO	USB1 Data 5	
74		MIO74_USB1_DATA6	IO	USB1 Data 6	
75		MIO75_USB1_DATA7	IO	USB1 Data 7	
76			MIO76_WLAN_IRQ	I	WL1831MOD WLAN Interrupt
77			PMIC_IRQ	I	PMIC_IRQ

5.1.3 Programmable Logic

Zynq UltraScale+ MPSoC Programmable Logic (PL) provides two types of I/O banks: High-density (HD) banks and high-performance (HP) banks. HD banks support a limited number of single-ended I/O standards with speeds up to 250Mbps and VCCO voltages up to 3.30V. HP banks support a large variety of high-speed I/O standards, including differential I/O, and support VCCO voltages up to 1.80V.

ZU3EG provides one HD bank with 24 pins, one HP bank with 52 pins, and another HP bank with 6 pins. All PL I/O banks is connected to expansion connectors.

Ultra96 provides two expansion connectors according to the 96Boards mezzanine standard:

- One low speed expansion connector connected to the HD bank
- One high speed expansion connector connected to the HP banks

5.1.3.1 Low Speed Expansion Connector

Ultra96 provides a 96Boards compatible Low Speed Expansion Connector. A Molex 87381-4063 (or compatible) 40 pin low profile female 2mm receptacle (20x2) 4.5mm height is specified. Table 3 shows the pinout of the Low Speed Expansion Header (Ultra96 column) and the differences from the 96Boards specification (96Boards column). With the exception of I2C0 and I2C1, all dedicated interfaces specified by 96Boards are replaced with GPIO.

Table 3 – Low Speed Expansion Connector

Ultra96	96Boards	Pin #	Pin #	96Boards	Ultra96
GND	GND	1	2	GND	GND
HD_GPIO0	UART0_CTS	3	4	PWR_BTN_N	PWR_BTN_N
HD_GPIO1	UART0_TxD	5	6	RST_BTN_N	RST_BTN_N
HD_GPIO2	UART0_RxD	7	8	SPI0_SCLK	PS_MIO38
HD_GPIO3	UART0_RTS	9	10	SPI0_DIN	PS_MIO42
HD_GPIO4	UART1_TxD	11	12	SPI0_CS	PS_MIO41
HD_GPIO5	UART1_RxD	13	14	SPI0_DOUT	PS_MIO43
PS_I2C0_SCL	I2C0_SCL	15	16	PCM_FS	HD_GPIO9
PS_I2C0_SDA	I2C0_SDA	17	18	PCM_CLK	HD_GPIO10
PS_I2C1_SCL	I2C1_SCL	19	20	PCM_DO	HD_GPIO11
PS_I2C1_SDA	I2C1_SDA	21	22	PCM_DI	HD_GPIO12
PS_MIO36	GPIO-A	23	24	GPIO-B	PS_MIO37
PS_MIO39	GPIO-C	25	26	GPIO-D	PS_MIO40
PS_MIO44	GPIO-E	27	28	GPIO-F	PS_MIO45
HD_GPIO6	GPIO-G	29	30	GPIO-H	HD_GPIO13
HD_GPIO7	GPIO-I	31	32	GPIO-J	HD_GPIO14
HD_GPIO8	GPIO-K	33	34	GPIO-L	HD_GPIO15
+1V8	+1V8	35	36	SYS_DCIN	SYS_DCIN
+5V0	+5V0	37	38	SYS_DCIN	SYS_DCIN
GND	GND	39	40	GND	GND

5.1.3.2 High Speed Expansion Connector

Ultra96 provides a 96Boards compatible High Speed Expansion Connector. An Amphenol FCI 61082-061409LF (or compatible) 60 pin low profile 0.8mm receptacle is specified.

Table 4 shows the pinout of the High Speed Expansion Header (Ultra96 column) and the differences from the 96Boards specification (96Boards column). With the exception of SD, I2C2 and I2C3, all dedicated interfaces specified by 96Boards are replaced with GPIO. All HP_GPIO are routed as differential pairs.

Table 4 – High Speed Expansion Connector

Xilinx	96Boards	Pin #
PS_SPIO_MOSI	SD_DAT0/SPI1_DOUT	1
n/c	SD_DAT1	3
n/c	SD_DAT2	5
PS_SPIO_CS	SD_DAT3/SPI1_CS	7
PS_SPIO_SCLK	SD_SCLK/SPI1_SCLK	9
PS_SPIO_MISO	SD_CMD/SPI1_DIN	11
GND	GND	13
HD_GPIO_CC	CLK0/CSI0_MCLK	15
HD_GPIO_CC	CLK1/CSI1_MCLK	17
GND	GND	19
HP_GPIO_CC+	DSI_CLK+	21
HP_GPIO_CC-	DSI_CLK-	23
GND	GND	25
HP_GPIO+	DSI_D0+	27
HP_GPIO-	DSI_D0-	29
GND	GND	31
HP_GPIO+	DSI_D1+	33
HP_GPIO-	DSI_D1-	35
GND	GND	37
HP_GPIO+	DSI_D2+	39
HP_GPIO-	DSI_D2-	41
GND	GND	43
HP_GPIO+	DSI_D3+	45
HP_GPIO-	DSI_D3-	47
GND	GND	49
USB_D+	USB_D+	51
USB_D-	USB_D-	53
GND	GND	55
HP_GPIO	HSIC_STR	57
HP_GPIO	HSIC_DATA	59

Pin #	96Boards	Xilinx
2	CSI0_C+	HP_GPIO+
4	CSI0_C-	HP_GPIO-
6	GND	GND
8	CSI0_D0+	HP_GPIO+
10	CSI0+D0-	HP_GPIO-
12	GND	GND
14	CSI0_D1+	HP_GPIO+
16	CSI0_D1-	HP_GPIO-
18	GND	GND
20	CSI0_D2+	HP_GPIO+
22	CSI0_D2-	HP_GPIO-
24	GND	GND
26	CSI0_D3+	HP_GPIO+
28	CSI0_D3-	HP_GPIO-
30	GND	GND
32	I2C2_SCL	PS_I2C0_SCL
34	I2C2_SDA	PS_I2C0_SDA
36	I2C3_SCL	PS_I2C1_SCL
38	I2C3_SDA	PS_I2C1_SDA
40	GND	GND
42	CSI1_D0+	HP_GPIO+
44	CSI1_D0-	HP_GPIO-
46	GND	GND
48	CSI1_D1+	HP_GPIO+
50	CSI1_D1-	HP_GPIO-
52	GND	GND
54	CSI1_C+	HP_GPIO+
56	CSI1_C-	HP_GPIO-
58	GND	GND
60	Reserved	Reserved

5.2 LPDDR4 Memory

Ultra96 provides 2GB (512Mbit x 32) of 533MHz (1066Mbps) LPDDR4 memory. A Micron MT53B512M32D2NP-062 WT:C is specified, migrating to MT53D512M32D2DS-053 WT:D in late 2018.

5.3 microSD Card

Ultra96 provides a microSD card socket as the primary boot device. VCCO for MIO1 is 1.80V thus a level shifter is required. A Maxim MAX13035E is used.

When available, the Ultra96 kit ships with a Delkin Devices “Utility” 16 GB Industrial MLC microSD card, pre-programmed with Linux boot. The Delkin Part Number is S416APG49-U3000-3, rated at Read Performance = 95MB/s and Write Performance = 55MB/s (measured using CrystalDiskMark).

There are several advantages to using MLC over the typical retail TLC that is readily available.

Table 5 – Comparison of TLC vs. MLC microSD Cards

	Retail TLC	Delkin Utility MLC
CrystalDiskMark Read Performance	80MB/s	95 MB/s
CrystalDiskMark Write Performance	20MB/s	55 MB/s
Lifecycle	<12 months	18-24 months
Endurance (Program/Erase cycles)	300-600	3000
SMART data enabled (card life stats)	No	Yes
Embedded mode – aligned to efficiently work with Linux based OS as opposed to FAT only	No	Yes

5.4 USB

Ultra96 provides one upstream (device) and two downstream (host) USB 3.0 connections. A USB 2.0 downstream (host) interface is provided on the high speed expansion bus.

Two Microchip USB3320 USB 2.0 ULPI Transceivers and one Microchip USB5744 4-Port SS/HS USB Controller Hub are specified.

Figure 3 below shows the Ultra96 USB Setup.

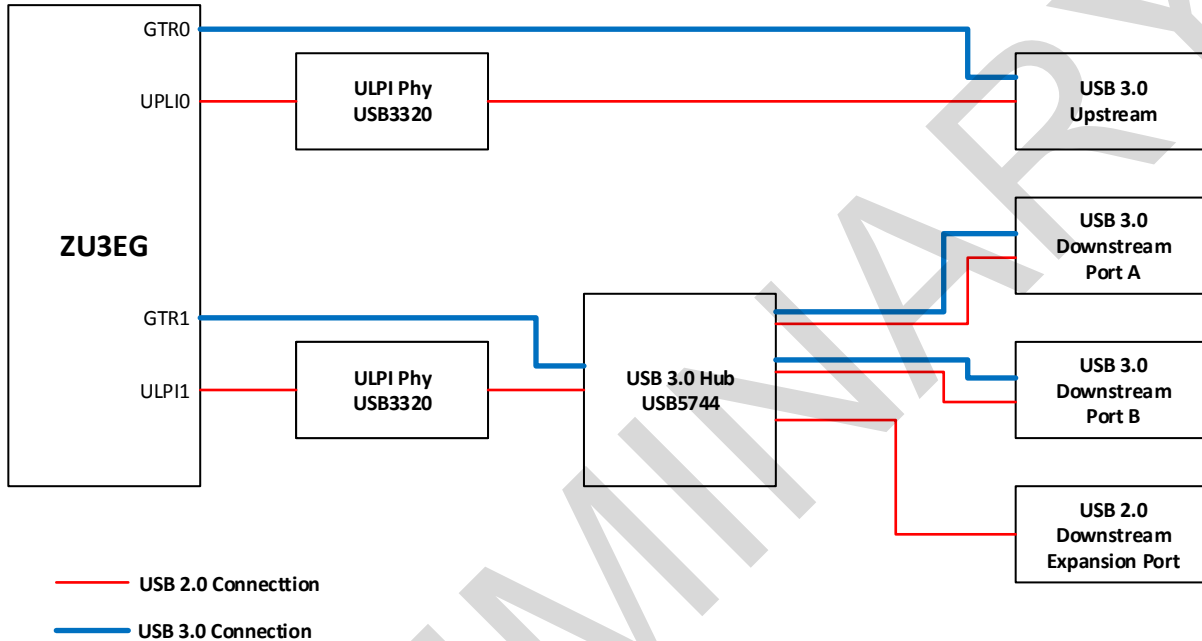

Figure 3 – USB Setup

5.4.1 USB5744 Implementation Details

Refer to the USB5744 datasheet (<http://ww1.microchip.com/downloads/en/DeviceDoc/00001855C.pdf>) and the EVB-USB5744 Evaluation Board schematics (http://ww1.microchip.com/downloads/en/DeviceDoc/EVB-USB5744_A1-sch.pdf) for implementation details.

NOTE: USB 3.0 Downstream Port A/B VUBS is controlled by a Microchip/Micrel MIC2009YML USB Power Switch following the Evaluation Board implementation

NOTE: USB2.0 Downstream Port VBUS is provided by the Low Speed Expansion Header 5V supply (see 5.1.3.1). A Power switch is not required and the corresponding USB5744 PRT_CTLx pin for that port is left n/c.

5.5 Wi-Fi / Bluetooth

Ultra96 supports Wi-Fi (802.11a/b/g/n) and Bluetooth 4.1.

A TI WL1831MOD WiLink 8 Single Band Combo Wi-Fi, Bluetooth & Bluetooth low energy module is specified.

5.5.1 Wi-Fi

The WL183xMOD WLAN interface connects to the MPSoC through the Secure Digital SD1 interface. The WLAN interrupt WL_IRQ is connected to PS MIO76, the WLAN enable signal WL_EN is connected to PS MIO7. A yellow LED is connected to WL_EN to indicate that Wi-Fi is enabled.

5.5.2 Bluetooth

The WL183xMOD Bluetooth interface connects through a UART interface. Since the Bluetooth UART interface requires hardware flow-control (RTS/CTS), which is only available through the PL, the UART RX/TX signals are connected to PS UART0 (MIO2, MIO3) and the RTS/CTS signals are connected to the PL High-Density (HD) bank. A blue LED is connected to BT_EN to indicate that Bluetooth is enabled.

5.5.3 Bluetooth Audio

WL183xMOD Bluetooth Audio connects through a PCM/I2S interface. Since MPSoC does not provide a PCM/I2S interface, this has to be implemented as a soft-IP core in the PL. The Bluetooth Audio is connected to the PL High-Density (HD) bank.

5.6 Mini DisplayPort

Ultra96 supports one Mini DisplayPort output. A TE Connectivity 2129320-3 provides the Mini DisplayPort connectivity.

5.7 UART

Ultra96 provides one UART. PS UART1 (MIO8, MIO9) is connected to a 3 pin 2mm header (J6).

5.8 I2C

Ultra96 supports one I2C bus. A TI TCA9544A Low-Voltage 8-Channel I2C Switch is specified to isolate the I2C sub-buses from each other. All I2C buses operate at 1.80V.

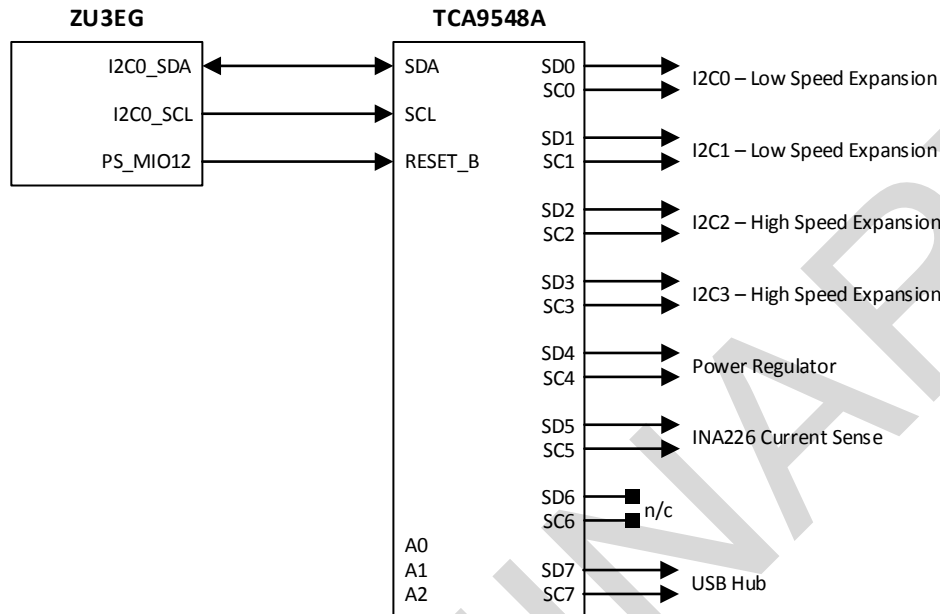

Figure 4 – MPSoC I2C to I2C Switch

5.9 User LEDs

Ultra96 provides four user-controllable LEDs connected to PS_MIO[17..20]. All User LEDs are green.

5.10 MPSoC Thermal Bracket with Fan

The Ultra96 uses a thermal bracket with fan for the MPSoC device. The bracket is mounted to the bottom side of the Ultra96 to help dissipate heat. A Sunon MC30060V1-000U-A99 fan is used, connected to 5V and GND at J18 and J19. Users can control the fan using signal FAN_PWM from PL IO F4 on Bank 65.

6 Configuration and Debug

6.1 Boot Mode

Ultra96 supports booting from JTAG, USB and microSD Card. A DIP switch (SW2) is installed to allow selecting the desired boot mode.

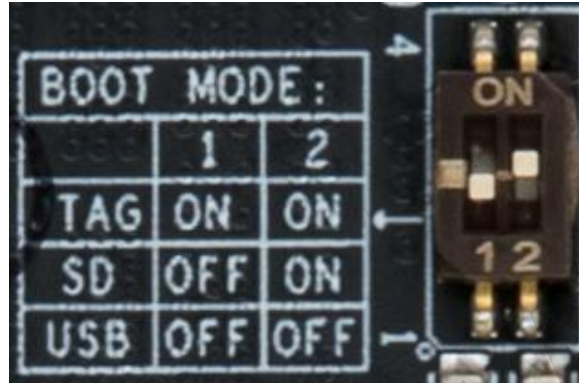

Figure 5 – Boot Mode Switch (SD Boot Mode Shown)

6.2 JTAG Configuration and Debug

JTAG access to the MPSoC is available through a 1x7 header (J2). An external JTAG pod with flyleads is required to interface to the board.

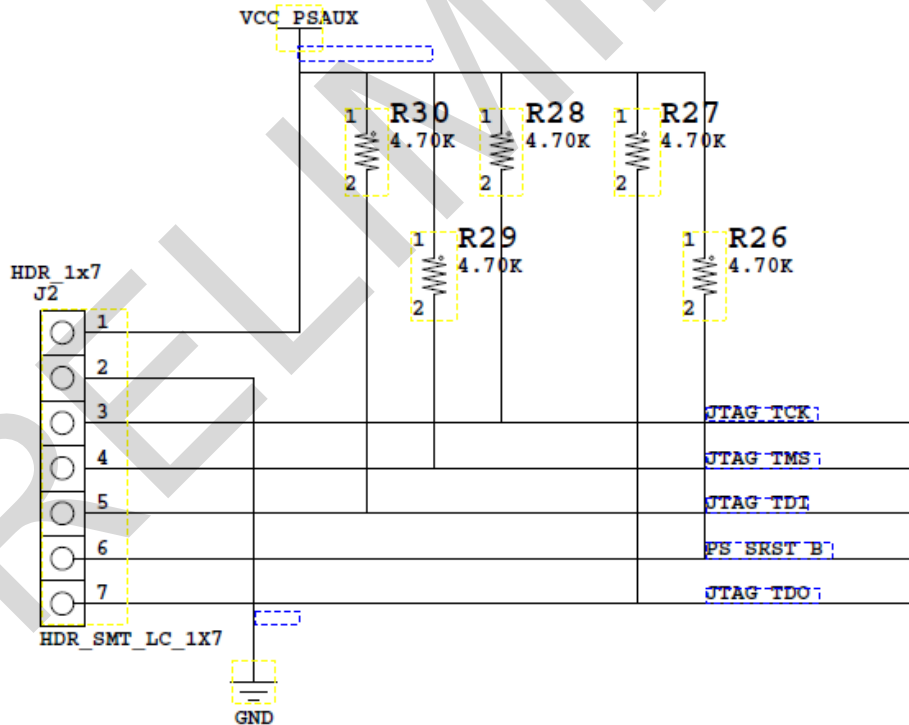

Figure 6 – Ultra96 JTAG Connection

7 Power

7.1 External Power Connection

Board power is supplied by an external 12V AC/DC Power Supply based on the 96Boards specification, located at <https://www.96boards.org/product/power/>.

Here are the requirements from the 96Boards site:

- EIAJ-3 compliant DC plug available up to 2A, which is 4.75 mm outer diameter with 1.7mm center pin (4.75/1.7), for the power supply
- https://en.wikipedia.org/wiki/EIAJ_connector

However, there is a bit of flexibility. Avnet offers a 12V supply as an accessory (part number: AES-ACC-U96-PWR) with the following specifications:

- Input: 100-240V, 50/60HZ
- US Plug 12V 2A power adapter
- 1.2m DC cable with ferrite
- 4.7mm * 1.7mm * 10 mm dc plug, Level VI



Figure 7 – Ultra96 12V @ 2A AC/DC Supply

7.2 Power Estimation Using XPE

Xilinx Power Estimator (XPE) should be used to generate worst case power estimations. The Xilinx Power Estimator (XPE) spreadsheet is available on Xilinx' website that can help you get started with your own power estimation. Avnet has also provided an example of this spreadsheet filled out for the Ultra96 under Documentation on the Ultra96 website.

7.3 Power Regulators

A configurable multi-rail PMIC provides all power for the Ultra96. The power rail configuration is shown below:

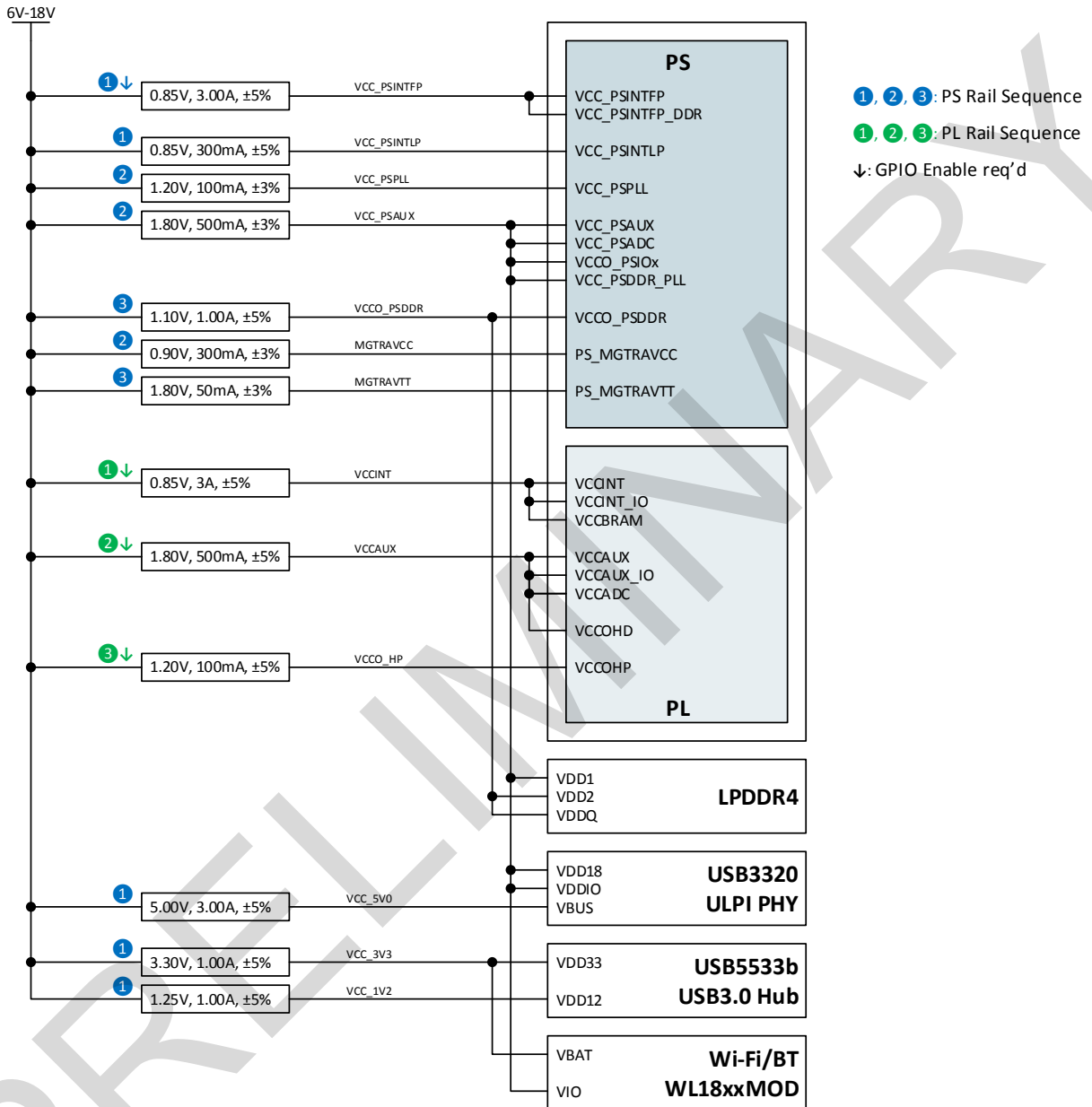

Figure 8 – Power Regulation

7.4 Power Sequence

The diagram below shows the power sequence:

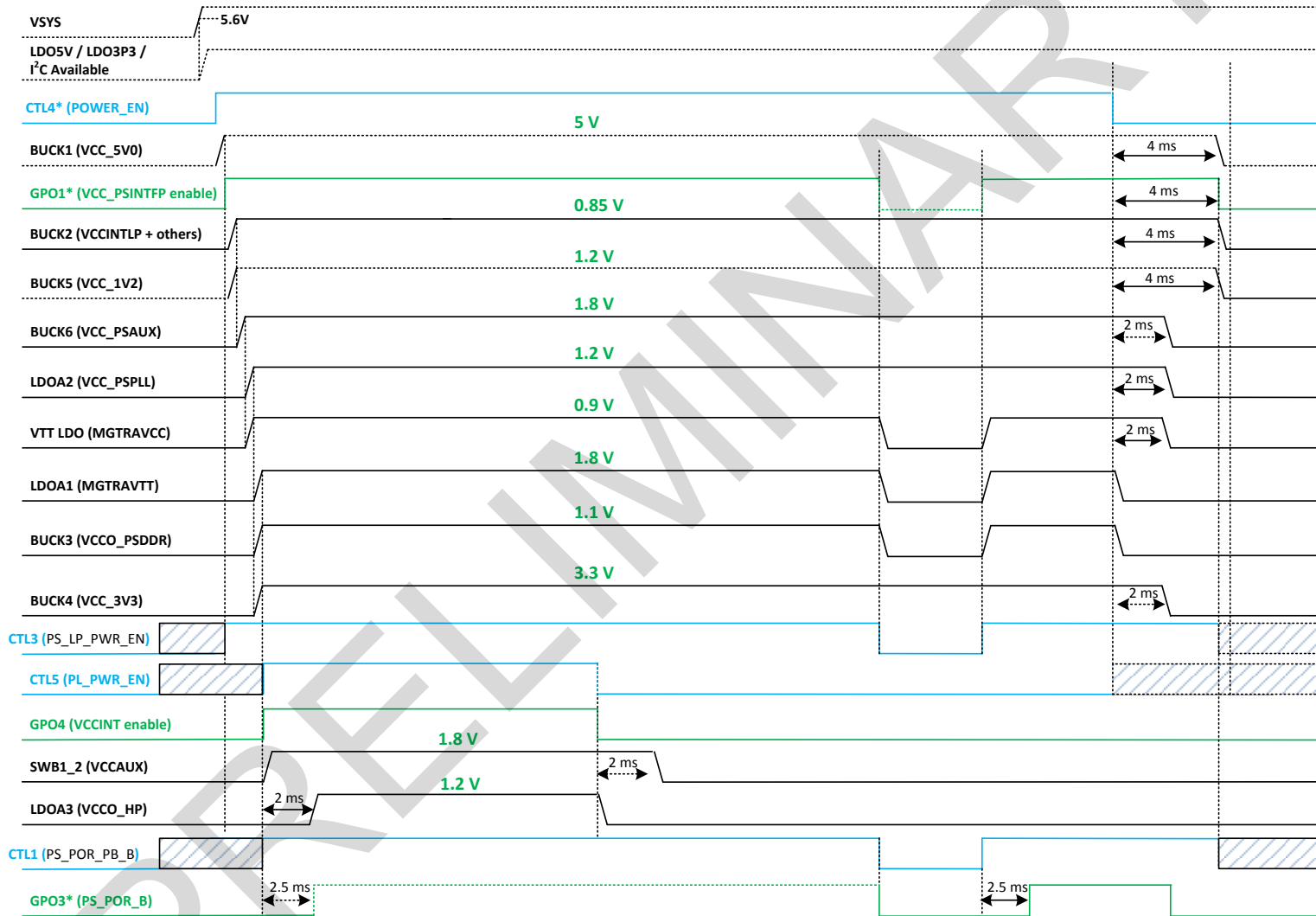

Figure 9 – Ultra96 Power Sequencing

8 Clocks

Ultra96 provides the following system clocks to the MPSoC:

- PS_CLK: PS reference clock 100MHz/3 (33.3MHz), 1.8V LVCMOS
- GTR_CLK0: USB3.0 26MHz, LVDS
- GTR_CLK1: DisplayPort 27MHz, LVDS

These clocks are generated by a Customizable Quad Clock Generator.

9 Reset

Ultra96 Reset is managed by the TI PMIC. At power-up, the ZU3EG is held in reset until all power rails have ramped up and are stable. A pushbutton allows manually resetting the ZU3EG.

10 Getting Help and Support

If additional support is required, Avnet has many avenues to search depending on your needs. For general question regarding Ultra96, please visit our website at www.ultra96.org. Here you can find documentation, technical specifications, videos and tutorials, reference designs and other support.

Detailed questions regarding Ultra96 hardware design, software application development, using Xilinx tools, training and other topics can be posted on the Ultra96 Support Forums at <http://www.picozed.org/forums/zed-english-forum>. Avnet's technical support team monitors the forum during normal business hours.

Those interested in customer-specific options on Ultra96 can send inquiries to customize@avnet.com.